

## Answer ALL questions.

All multiple choice questions must be answered with a cross  $\boxtimes$  in the box for the correct answer from A to D. If you change your mind about an answer, put a line through the box  $\boxtimes$  and then mark your new answer with a cross  $\boxtimes$ .

- 1 Part of an electric circuit is shown.

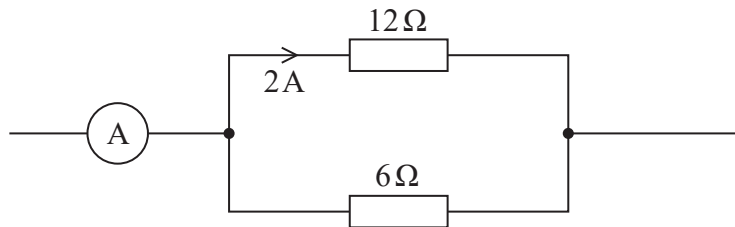

What is the current shown by the ammeter?

- A 3 A  
 B 4 A  
 C 5 A  
 D 6 A

(Total for Question 1 = 1 mark)

- 2 A cell is connected across a resistor. After a while the internal resistance of the cell increases.

Which row of the table correctly shows the change in the current in the circuit and the change in the terminal potential difference across the cell?

	Current	Terminal potential difference
<input type="checkbox"/> A	decreases	decreases
<input type="checkbox"/> B	decreases	increases
<input type="checkbox"/> C	increases	decreases
<input type="checkbox"/> D	increases	increases

(Total for Question 2 = 1 mark)



3 An object is falling at terminal velocity.

Which of the following is **not** a valid conclusion from this statement?

- A The acceleration of the object is zero.
- B There is a resistive force acting on the object.
- C There is a resultant force acting on the object.
- D The object has weight.

(Total for Question 3 = 1 mark)

4 A light dependent resistor is connected across a cell of negligible internal resistance. The light intensity is increased.

Which of the following statements about the current is correct?

- A It decreases because there is an increase in the number of conduction electrons.
- B It increases because there is an increase in the number of conduction electrons.
- C It decreases because the amplitude of lattice vibrations decreases.
- D It increases because the amplitude of lattice vibrations increases.

(Total for Question 4 = 1 mark)

5 Which of the following graphs shows how the current varies with potential difference for a filament lamp?

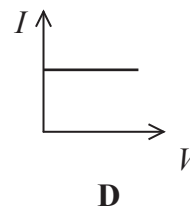
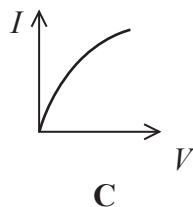
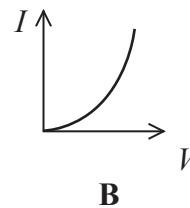
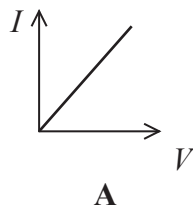

- A
- B
- C
- D

(Total for Question 5 = 1 mark)



6 Which of the following are the base units for impulse?

- A  $\text{kg m s}^{-1}$
- B  $\text{kg m s}^{-2}$
- C  $\text{Nm}$
- D  $\text{Ns}$

(Total for Question 6 = 1 mark)

7 A potential difference  $V$  is applied across two parallel plates. An electron midway between the two plates at point X experiences an electric force  $F$ .

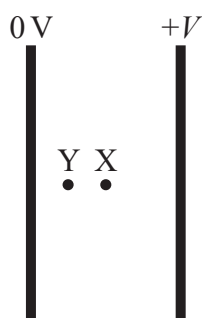

The electron moves to point Y which is halfway between point X and the left-hand plate.

Which of the following is the electric force experienced by the electron at Y?

- A  $2F$
- B  $F$
- C  $\frac{F}{2}$
- D  $\frac{F}{4}$

(Total for Question 7 = 1 mark)

8 A wire carries an alternating current of peak value 3 A.

Which of the following is the root-mean-square value of this current?

- A 1.5 A
- B 2.1 A
- C 4.2 A
- D 9.0 A

(Total for Question 8 = 1 mark)

DO NOT WRITE IN THIS AREA

DO NOT WRITE IN THIS AREA

DO NOT WRITE IN THIS AREA



11 A “metre bridge” is a circuit which can be used to measure an unknown resistance accurately. The metre bridge includes a metre length of nichrome wire.

(a) Calculate the resistance of a 1.00 m length of the nichrome wire.

(3)

resistivity of nichrome =  $1.12 \times 10^{-6} \Omega\text{m}$   
 diameter of wire =  $4.00 \times 10^{-4} \text{m}$

.....

.....

.....

.....

.....

Resistance = .....

(b) This metre length of wire, labelled AB, is connected to a 1.50 V cell of negligible internal resistance and a switch as shown.

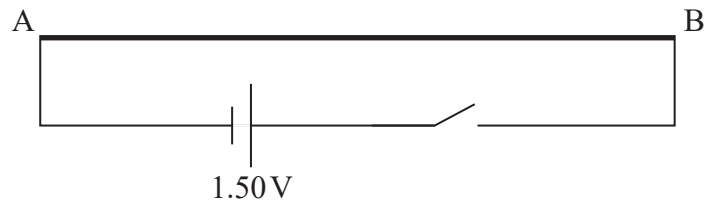

(i) Explain how the potential along this wire varies with distance from A when the switch is closed.

(2)

.....

.....

.....

.....

(ii) Show that the potential difference between A and a point 75.0 cm along the wire from A is about 1.1 V.

(2)

.....

.....

.....

.....

DO NOT WRITE IN THIS AREA

DO NOT WRITE IN THIS AREA

DO NOT WRITE IN THIS AREA



- (c) The metre bridge circuit is shown. The circuit includes a resistor of resistance  $3.30\ \Omega$ , a very sensitive ammeter and a resistor of unknown resistance  $R$ .

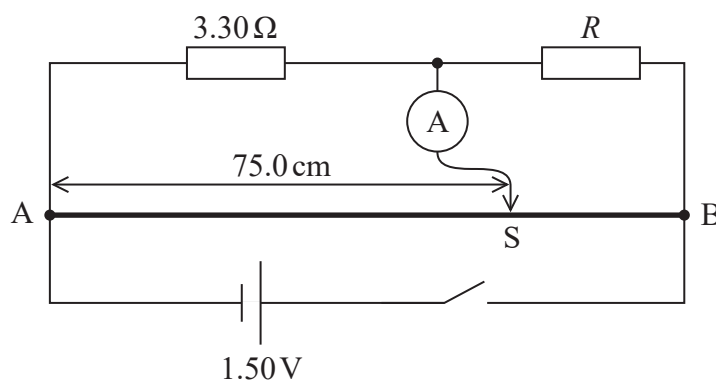

A metal slider  $S$  can be moved along the nichrome wire and pressed firmly against it to make an electrical connection.

When the switch is closed and  $S$  is  $75.0\text{ cm}$  along the nichrome wire, the ammeter reads  $0\text{ A}$  because the potential difference across the ammeter is zero.

Calculate  $R$ .

(2)

$R = \dots\dots\dots$

**(Total for Question 11 = 9 marks)**

DO NOT WRITE IN THIS AREA

DO NOT WRITE IN THIS AREA

DO NOT WRITE IN THIS AREA





- 5 A cell of e.m.f.  $1.5\text{ V}$  is connected to a  $5.0\Omega$  resistor. The terminal potential difference across the cell is  $1.0\text{ V}$ .

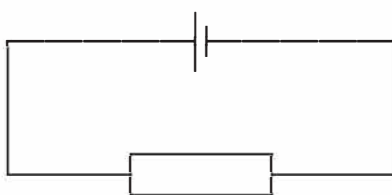

Which of the following is the current in the circuit?

- A  $0.1\text{ A}$   
 B  $0.2\text{ A}$   
 C  $0.3\text{ A}$   
 D  $0.5\text{ A}$

(Total for Question 5 = 1 mark)

- 6 The diagram shows a graph of current  $I$  against potential difference  $V$  for an electrical component.

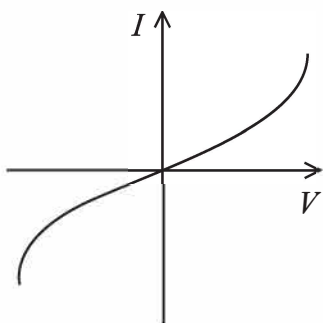

Which of the following components would produce a graph of this shape?

- A filament bulb  
 B metallic conductor  
 C negative temperature coefficient thermistor  
 D ohmic conductor

(Total for Question 6 = 1 mark)

DO NOT WRITE IN THIS AREA

DO NOT WRITE IN THIS AREA

DO NOT WRITE IN THIS AREA



15 The graph shows how current varies with potential difference (p.d.) for an ideal diode.

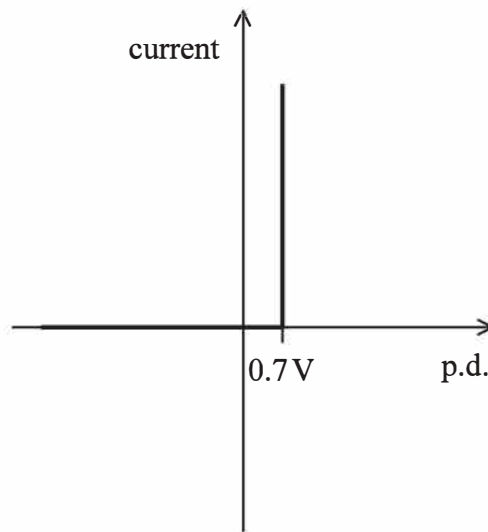

(a) Describe how the current through this diode varies for positive p.d.s and negative p.d.s. (2)

.....

.....

.....

.....

(b) An alternating p.d.  $V_{IN}$  has a peak value of 3.4 V.

(i) Calculate the r.m.s. value.

(2)

r.m.s. value = .....

(ii)  $V_{IN}$  is applied to a diode and resistor as shown.

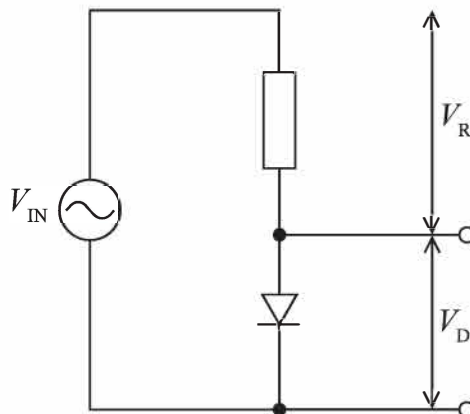

DO NOT WRITE IN THIS AREA

DO NOT WRITE IN THIS AREA

DO NOT WRITE IN THIS AREA



The p.d. across the resistor is  $V_R$  and the p.d. across the diode is  $V_D$ .  $V_D$  is the output.

Explain why  $V_{IN} = V_R + V_D$  at any given time.

(2)

(iii) The graph shows how  $V_{IN}$  varies with time.

Sketch a graph of  $V_D$  against time using the axes provided below.

(3)

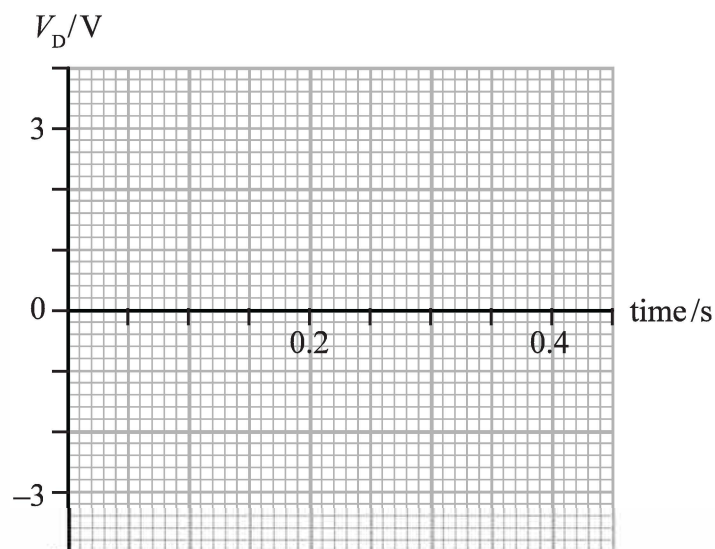
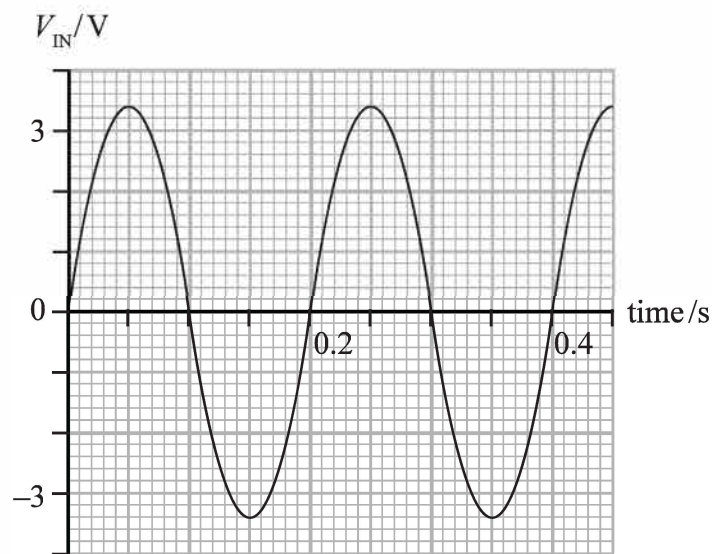

(Total for Question 15 = 9 marks)



- 7 The intensity of light incident on a light dependent resistor (LDR) can vary both its electrical resistance  $R$  and the number of charge carriers per unit volume  $n$ . The light intensity on an LDR is increased.

Which row of the table describes the effect on  $R$  and  $n$ ?

	<b>R</b>	<b>n</b>
<input type="checkbox"/> A	decreases	decreases
<input type="checkbox"/> B	decreases	increases
<input type="checkbox"/> C	increases	decreases
<input type="checkbox"/> D	increases	increases

(Total for Question 7 = 1 mark)

- 8 A proton has a mass of  $1.67 \times 10^{-27}$  kg.

Which of the following shows the conversion of this mass to  $\text{GeV}/c^2$  ?

- A  $\frac{1.67 \times 10^{-27} \times 1.60 \times 10^{-10}}{(3.00 \times 10^8)^2}$
- B  $\frac{1.67 \times 10^{-27} \times 1.60 \times 10^{-19}}{(3.00 \times 10^8)^2}$
- C  $\frac{1.67 \times 10^{-27} \times (3.00 \times 10^8)^2}{1.60 \times 10^{-10}}$
- D  $\frac{1.67 \times 10^{-27}}{1.60 \times 10^{-10} \times (3.00 \times 10^8)^2}$

(Total for Question 8 = 1 mark)

- 9 The blade of a lawnmower rotates at a speed of 50 revolutions per second.

Which of the following is the angular speed of the blade in  $\text{rads s}^{-1}$ ?

- A 7.96
- B 15.9
- C 157
- D 314

(Total for Question 9 = 1 mark)



- 12 Analogue ammeters were used before digital meters became widely available. The analogue ammeter shown will measure a maximum current of 1.0 mA and has a resistance of  $18\ \Omega$ .



(Source: © David J. Green/Alamy Stock Photo)

The analogue ammeter can be adapted to measure a larger current by adding a resistor, known as a shunt, in parallel with the ammeter. The arrangement is shown below. The analogue ammeter is represented by the  $18\ \Omega$  resistor.

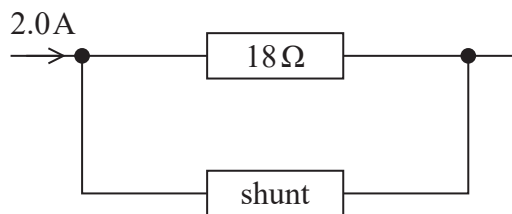

The maximum current through the  $18\ \Omega$  resistor remains as 1.0 mA.

- (a) Show that the shunt would need to have a resistance of about  $0.01\ \Omega$  to adapt this ammeter to read up to a maximum current of 2.0 A.

(3)

.....

.....

.....

.....

.....

.....



(b) A shunt of this resistance was usually made from Manganin wire.

Calculate the length of Manganin wire of radius 0.95 mm required to make this shunt.

resistivity of Manganin =  $4.55 \times 10^{-7} \Omega \text{m}$

(3)

Length = .....

**(Total for Question 12 = 6 marks)**

DO NOT WRITE IN THIS AREA

DO NOT WRITE IN THIS AREA

DO NOT WRITE IN THIS AREA



**Questions 4 and 5 refer to the information below.**

Two resistors are connected in parallel and the current in one of them is 2.0 A, as shown.

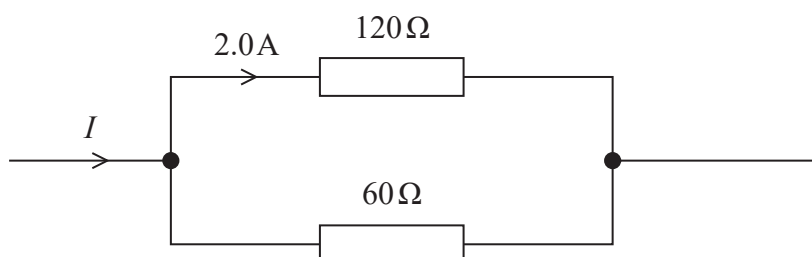

4 Which of the following is the current  $I$  in ampere?

- A 3.0
- B 4.0
- C 5.0
- D 6.0

(Total for Question 4 = 1 mark)

5 Which of the following is the total resistance of the resistors in parallel?

- A  $20\ \Omega$
- B  $40\ \Omega$
- C  $90\ \Omega$
- D  $180\ \Omega$

(Total for Question 5 = 1 mark)

DO NOT WRITE IN THIS AREA

DO NOT WRITE IN THIS AREA

DO NOT WRITE IN THIS AREA



- 7 A light dependent resistor (LDR) and a resistor are connected to a battery, as shown.

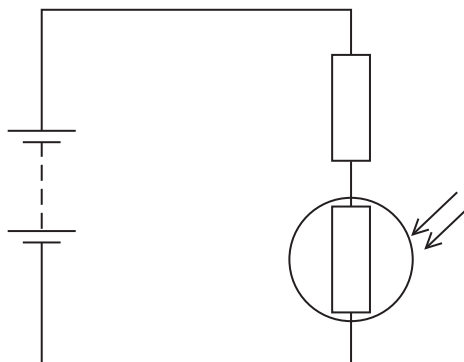

The intensity of light incident on the LDR increases.

Which row of the table describes the change in the resistance of the LDR and the change in the potential difference across the resistor?

	Resistance of LDR	Potential difference across the resistor
<input type="checkbox"/> A	decreases	decreases
<input type="checkbox"/> B	decreases	increases
<input type="checkbox"/> C	increases	decreases
<input type="checkbox"/> D	increases	increases

(Total for Question 7 = 1 mark)

- 8 A potential difference is applied across two parallel plates. A particle carrying a charge of  $+0.1\text{ C}$  is placed between the plates and experiences a force  $F$ .

The distance between the plates is halved. The potential difference remains constant.

Which of the following is now equal to the electric field strength between the plates?

- A  $5F$
- B  $10F$
- C  $20F$
- D  $40F$

(Total for Question 8 = 1 mark)



14 The world solar challenge is set every two years, in Australia. The challenge is to complete a three thousand kilometre route with a vehicle powered only by the Sun.

Vehicles have their surfaces fitted with solar panels, as shown in the photograph.

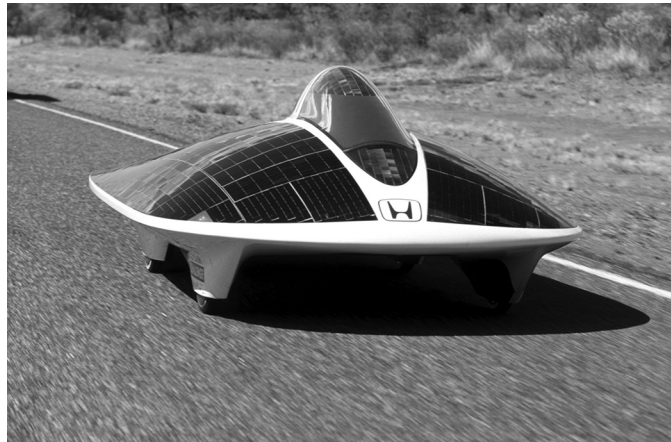

(Source: © LAURENT DOUEK/LOOK AT SCIENCES/SCIENCE PHOTO LIBRARY)

(a) One of the solar panels has an e.m.f. of 8.2 V when in sunlight. The terminal potential difference is 5.5 V when a current of 0.45 A is drawn from the solar panel.

Calculate the internal resistance of the solar panel in these conditions.

(3)

.....

.....

.....

Internal resistance = .....

(b) A bank of 380 of these solar panels is used to charge the battery in a vehicle. The panels are connected in parallel and the current provided by each panel is 0.45 A. When fully charged, the energy stored in the battery is 12 kWh.

Calculate the time, in hours, to fully charge this battery if the solar panels are in sunlight. Assume the efficiency of charging this battery is 100%.

(3)

.....

.....

.....

.....

.....

Time = ..... hours

DO NOT WRITE IN THIS AREA

DO NOT WRITE IN THIS AREA

DO NOT WRITE IN THIS AREA



(c) The vehicle can reach a maximum speed of  $34 \text{ m s}^{-1}$  on flat ground. The electric motor used to move the vehicle has a power of  $4.5 \text{ kW}$ .

(i) Calculate the initial acceleration of the vehicle as it starts from rest.

mass of vehicle and driver =  $420 \text{ kg}$

(3)

Initial acceleration = .....

(ii) State one assumption made in this calculation.

(1)

(d) Solar power alone would not be suitable for a family car because it is not sunny all the time.

Give two further reasons why solar power alone would not be suitable.

(2)

(Total for Question 14 = 12 marks)



14 Power supplies provide either alternating or direct currents and potential differences.

(a) A power supply produces an alternating potential difference (p.d.). The p.d. has a period of 0.02 s and a peak value of 4.0 V.

(i) Calculate the frequency of the supply.

(1)

Frequency = .....

(ii) Calculate the root-mean-square p.d.

(1)

Root-mean-square p.d. = .....

(b) It is possible to convert alternating currents and p.d.s, to direct currents and p.d.s using diodes.

The power supply provides an input  $V_{in}$  to the circuit shown. The circuit includes four diodes  $D_1$ ,  $D_2$ ,  $D_3$  and  $D_4$  and a resistor  $R$ . The circuit produces an output potential difference  $V_{out}$ .

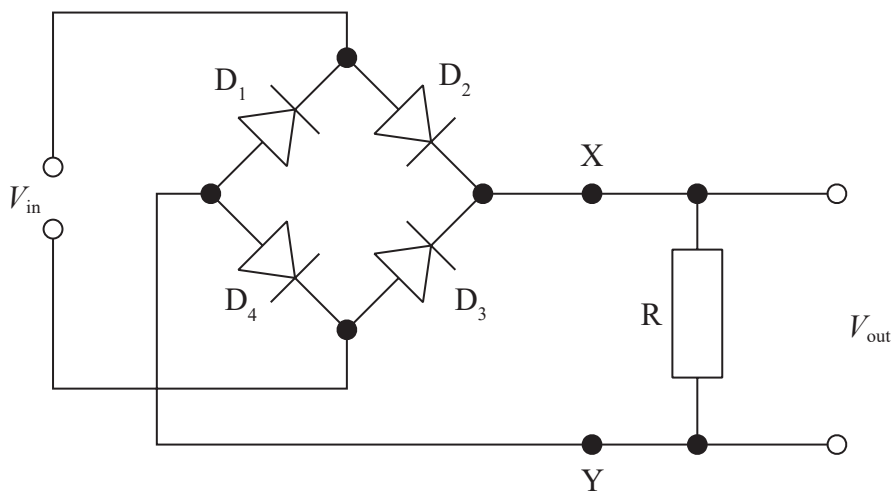

A graph of  $V_{in}$  against time and a corresponding graph of  $V_{out}$  against time are shown below.

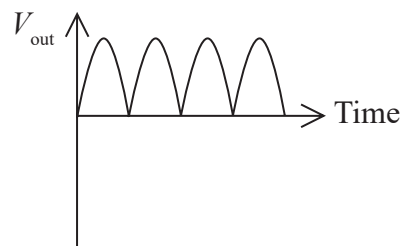
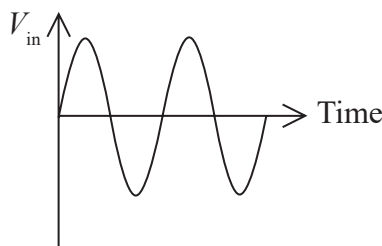

(i) Explain the operation of this circuit. Your answer should refer to  $D_1$ ,  $D_2$ ,  $D_3$  and  $D_4$ .

(3)

(ii) A capacitor is added between points X and Y in the circuit.

The new graph of  $V_{out}$  against time is shown below.

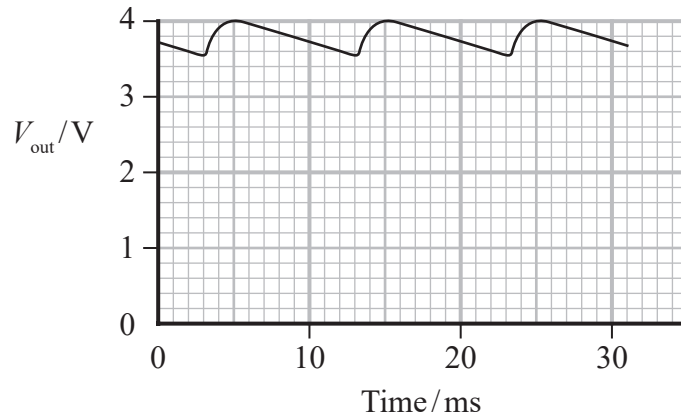

Determine a value for the capacitance of the capacitor.

resistance of  $R = 2.2\text{ k}\Omega$

(3)

Capacitance = .....

(Total for Question 14 = 8 marks)

DO NOT WRITE IN THIS AREA

DO NOT WRITE IN THIS AREA

DO NOT WRITE IN THIS AREA



- 18 A potential divider circuit may contain a component known as a potentiometer. One type of potentiometer consists of a track with terminals X and Y at either end. There is a sliding contact that can move along the track connected to a terminal Z as shown.

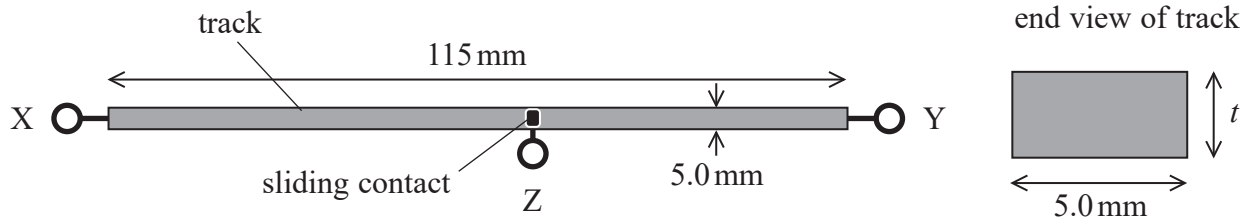

The length of the track is 115 mm and the width is 5.0 mm.

- (a) The resistance of the track between terminal X and terminal Y is  $12.0 \text{ k}\Omega$ .

Calculate the thickness  $t$  of the track.

resistivity of track material =  $0.49 \text{ }\Omega \text{ m}$

(3)

$t = \dots\dots\dots$

DO NOT WRITE IN THIS AREA

DO NOT WRITE IN THIS AREA

DO NOT WRITE IN THIS AREA



- (b) The potentiometer is used to monitor the displacement of a moving tool on a machine in a production line. The tool is attached to the sliding contact. The potentiometer is connected to a resistor of resistance  $R$  and a potential difference is applied as shown. The tool moves through a maximum displacement of 60 mm from end X, producing a maximum potential difference of 5.0 V between Z and X.

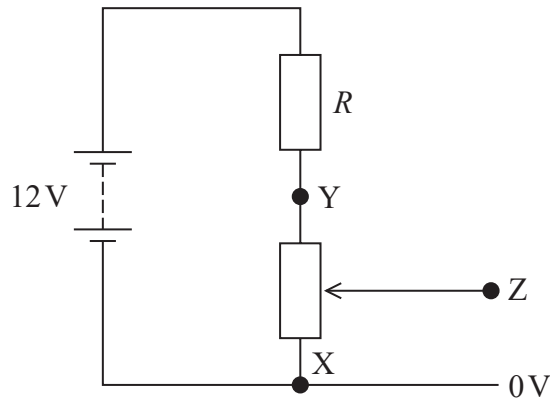

- (i) Show that the potential difference between X and Y is about 10 V.

(2)

- (ii) Calculate the value of  $R$ .

(3)

$$R = \dots\dots\dots$$

DO NOT WRITE IN THIS AREA

DO NOT WRITE IN THIS AREA

DO NOT WRITE IN THIS AREA



- (iii) When the circuit is assembled, using the correctly calculated resistance value and a battery of e.m.f. 12 V, it is found that the maximum output from the potentiometer is slightly less than 5.0 V.

Explain why the maximum output is slightly less than predicted.

(3)

- (iv) The tool on the machine should not travel with a speed any larger than  $0.8 \text{ m s}^{-1}$ .

The graph shows how the displacement varies with time for the downward stroke of the moving tool.

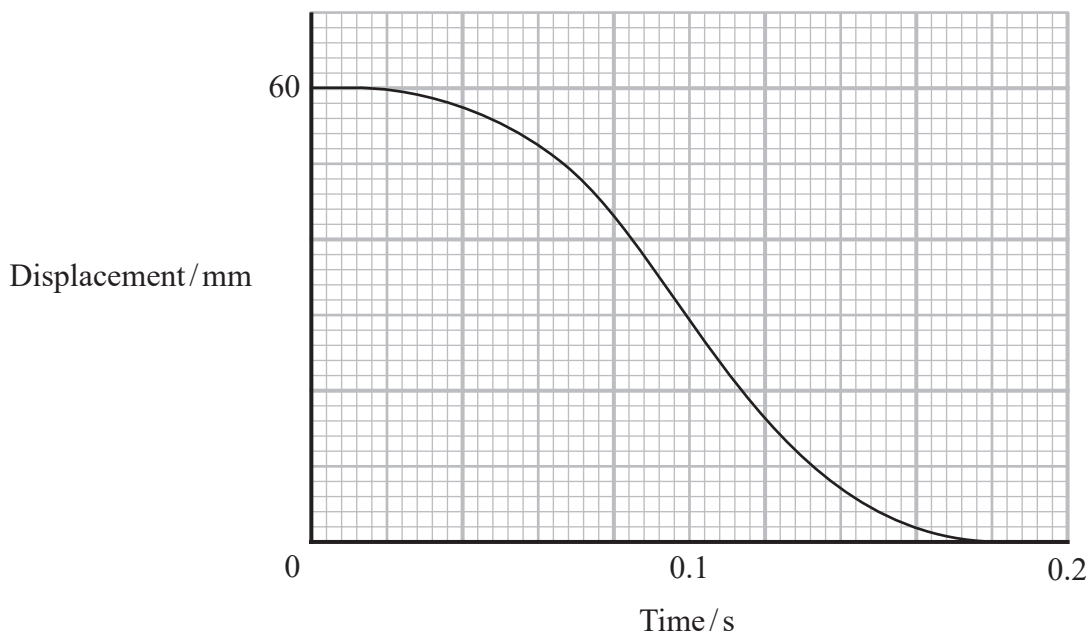

DO NOT WRITE IN THIS AREA

DO NOT WRITE IN THIS AREA

DO NOT WRITE IN THIS AREA



Deduce whether this speed is exceeded by the moving tool.

(4)

DO NOT WRITE IN THIS AREA

DO NOT WRITE IN THIS AREA

DO NOT WRITE IN THIS AREA

(Total for Question 18 = 15 marks)

**TOTAL FOR PAPER = 90 MARKS**



- 6 In a boiler, energy is transferred to water at a rate of 40 kW. The corresponding power loss from the boiler to the surroundings is 4.0 kW.

Which of the following is the efficiency of this boiler?

- A 0.10
- B 0.11
- C 0.90
- D 0.91

(Total for Question 6 = 1 mark)

- 7 A car is fitted with an airbag which will inflate if the car stops very suddenly.



(Source: © KAIROS, LATIN STOCK/SCIENCE PHOTO LIBRARY)

Which of the following is increased if the airbag inflates because the car suddenly stops?

- A change in momentum of the driver
- B change in velocity of the driver
- C force on the driver
- D time that the driver takes to stop

(Total for Question 7 = 1 mark)



12 An electrical conductor XY carries a current  $I$  as shown.

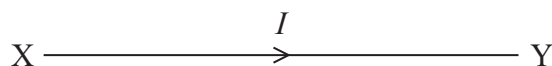

The current density  $j$  is defined as  $j = \frac{I}{A}$  where  $A$  is the cross-sectional area of the conductor.

(a) Current density is a vector quantity.

State what is meant by a vector quantity.

(1)

(b)  $I$  is constant but  $A$  decreases towards end Y.

Explain how this affects the drift velocity of the free electrons in the conductor.

(2)

DO NOT WRITE IN THIS AREA

DO NOT WRITE IN THIS AREA

DO NOT WRITE IN THIS AREA



(c) The resistivity  $\rho$  of the conducting material is given by  $\rho = \frac{E}{j}$

where  $E$  is the electric field strength.

Show that the units are the same on both sides of this equation.

(4)

.....

.....

.....

.....

.....

.....

.....

.....

.....

.....

**(Total for Question 12 = 7 marks)**

DO NOT WRITE IN THIS AREA



- 13 The circuit shown provides an input to a transistor. A transistor is a type of electronic switch and in this circuit it can be assumed to have infinite resistance.

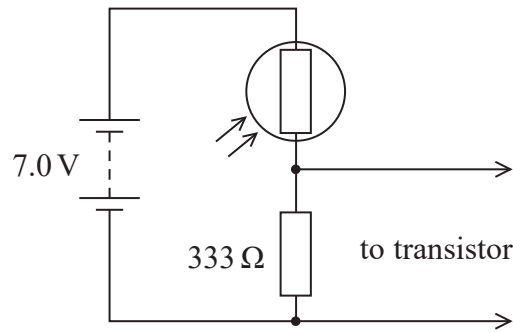

The resistance of the LDR varies with light level as shown below.

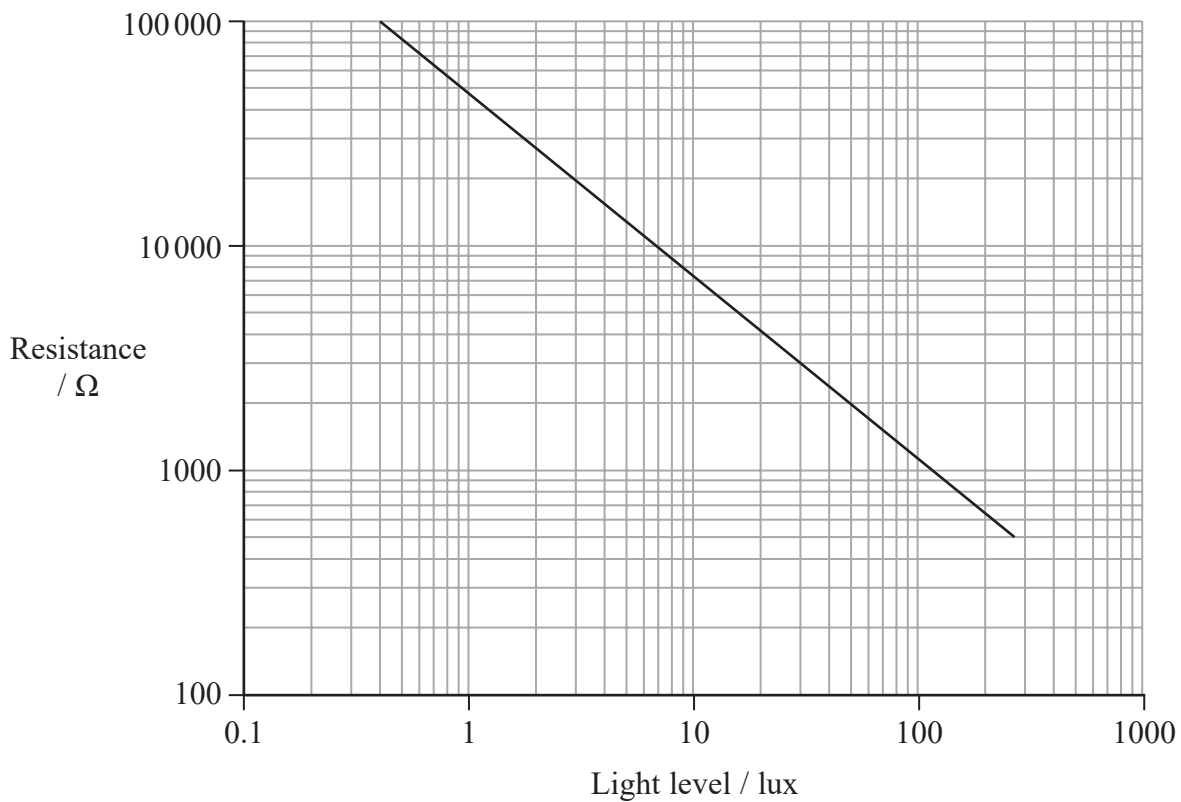

The transistor switches on when the potential difference across the input increases above 0.7 V. This should happen as the light level reaching the LDR increases above 30 lux.

DO NOT WRITE IN THIS AREA

DO NOT WRITE IN THIS AREA

DO NOT WRITE IN THIS AREA





- 18 The circuit shows a 1 mF capacitor connected to an a.c. supply. The graph shows how the potential difference  $V$  varies with time  $t$ .

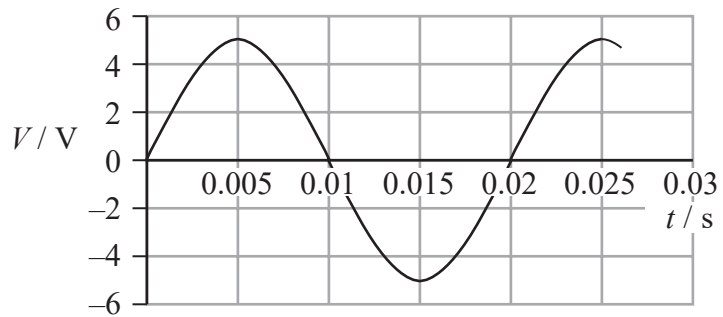
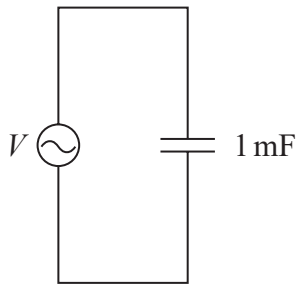

- (a) (i) Calculate the root-mean-square potential difference.

(1)

Root-mean-square potential difference = .....

- (ii) The formula used to generate this graph is  $V = 5 \sin(100\pi t)$

Explain why this formula leads to the graph above.

(3)

DO NOT WRITE IN THIS AREA

DO NOT WRITE IN THIS AREA

DO NOT WRITE IN THIS AREA



- (b) A spreadsheet is used to model how the current  $I$  in the 1 mF capacitor varies with  $t$ . Six rows of the spreadsheet are shown below.

	A	B	C	D	E	F	G
	$t / \text{s}$	$\Delta t / \text{s}$	$V / \text{V}$	$Q_{\text{initial}} / \text{C}$	$Q_{\text{final}} / \text{C}$	$\Delta Q / \text{C}$	$I / \text{A}$
7	0.0050	0.0010	5.00	0.00476	0.00500	0.00024	0.24
8	0.0060	0.0010	4.76	0.00500	0.00476	-0.00024	-0.24
9	0.0070	0.0010	4.05	0.00476	0.00405	-0.00071	-0.71
10	0.0080	0.0010	2.94	0.00405	0.00294	-0.00111	-1.11
11	0.0090	0.0010	1.55	0.00294	0.00155	-0.00139	-1.39
12	0.0100	0.0010	0	0.00155	0.00000	-0.00155	-1.55

- (i) Explain how cell E10 has been calculated.

(2)

- (ii) State the formula used to calculate cell G11.

(1)

- (iii) Calculate the maximum energy stored on the capacitor.

(2)

Maximum energy stored on the capacitor = .....



